

Temperature Monitoring

The latest beacon models include support for connection to a Temperature Sensor which supports the 1-Wire communications protocol.

Fleet Managers now have the ability to monitor temperature-sensitive cargo, and receive alerts in the portal if configurable temperature thresholds are violated.

Temperature Sensor

The 1-Wire Temperature Sensor recommended for use with beacons is manufactured by Embedded Data Systems. Sensors may be obtained by following this link:

http://www.embeddeddatasystems.com/OW-TEMP-S3-12x--Temperature-Probe_p_41.html

Full Specifications for the probe may be found here:

<http://www.embeddeddatasystems.com/assets/images/supportFiles/manuals/OW-TEMP-SProbe.pdf>



1. Sensor Installation and Testing

The 1-Wire data connection on the Beacon is located on Pin 6 on the wiring harness, which is attached to the beige wire in the bundle. This wire should be connected to the data wire on the Temperature Sensor, which is the blue colored wire on the recommended Embedded Data Systems device. The other two wires that come with the sensor device (white and orange) should both be connected to Ground.

Please refer to the Temperature Sensor Wiring Diagram on the next

Supported Beacons

The 1-Wire Temperature Alert feature is currently available on the following beacon models:
6500, 6501 (2G GPRS)
6550, 6551 (3G HSPA)



Temperature Sensor Wiring Diagram

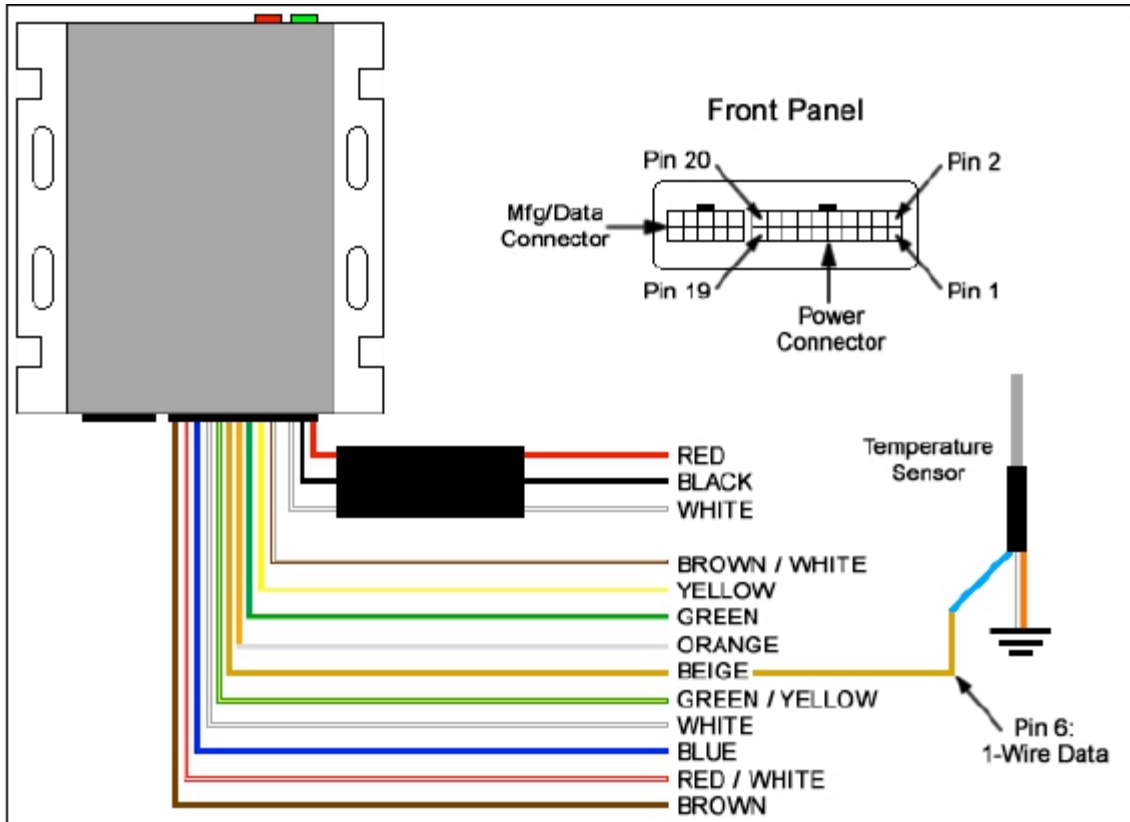

Once installed, the Temperature Sensor may be tested using the Beacon Test page in the Partner Portal, or by using the Mobile Beacon Test Tool. A fourth test has been added to the tool, which when used will send a message to the beacon to test the sensor. If the test passes, the current temperature read by the sensor is returned. If a wiring error is detected this will be reported. Or, if the sensor cannot be found, a connectivity error is reported.

Beacon Test Tools – Temperature Sensor Test

Test 4 (optional): Temperature Sensor Status

If a temperature sensor is connected to the beacon, this test checks the wiring and returns the current temperature reading if the sensor is correctly installed.

2. Scenario Configuration

In order to receive alerts, a Temperature Sensor Alert scenario must be configured. The user selects the default unit for configuration (Fahrenheit or Celsius), which also applies to event reporting.

The user must enter at least one Temperature Threshold when configuring the scenario. If the temperature reported by the sensor is greater than the “Above Threshold” for a user-defined period of time, an alarm event is generated. Similarly, an alarm is generated if the temperature is less than the “Below Threshold” for a user-defined period of time.

In both cases the period of time, called the “Threshold Duration”, is configurable in a range from 5 seconds, which is the equivalent of the alarm being generated immediately, up to 15 minutes.

As part of scenario configuration, e-mail and/or SMS text notifications may be configured for Temperature Sensor events in the same manner as other events supported by the beacon. Temperature Sensor events may be configured to raise Incidents at the monitoring station if this feature is included in the service plan.

The schedule for the Temperature Sensor Alert scenario is always 24 x 7.

Temperature Sensor Alert Scenario Configuration

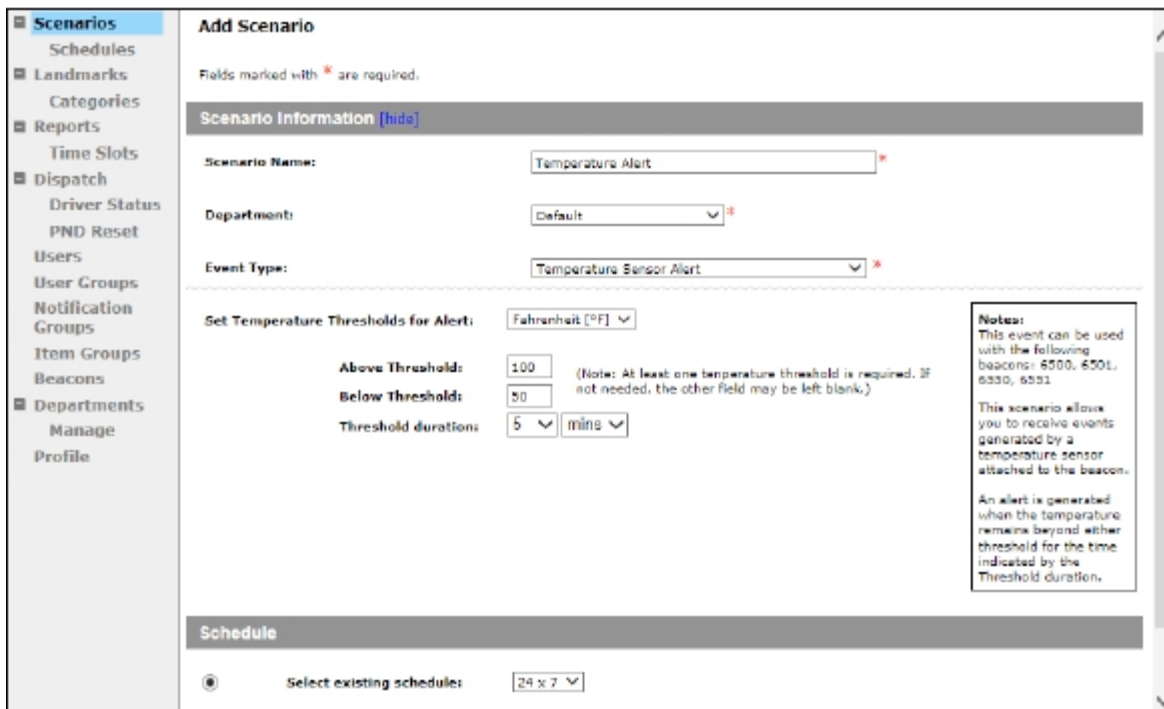

Add Scenario

Fields marked with * are required.

Scenario Information [hide]

Scenario Name: *

Department: *

Event Type: *

Set Temperature Thresholds for Alert:

Above Thresholds: (Note: At least one temperature threshold is required. If not needed, the other field may be left blank.)

Below Thresholds:

Threshold durations:

Notes:
 This event can be used with the following beacons: 6500, 6501, 6530, 6531
 This scenario allows you to receive events generated by a temperature sensor attached to the beacon.
 An alert is generated when the temperature remains beyond either threshold for the time indicated by the Threshold duration.

Schedule

Select existing schedules:

3. Event Reporting

All Temperature Sensor Alert events and Defective Temperature Sensor events are recorded for later reporting in the Portal. The example on the next page shows Temperature Sensor Alert events displayed in the Event Detail Report.

Event Detail Report – Temperature Sensor Alert

Event Detail Report				cancel	print	export...
Time Period: 09/17/2013 04:15PM to 09/17/2013 05:00PM Item Name: 1915-Office3 Beacon Name: 1915-Office3 Grouped By: Event				Report Summary Temperature Sensor Alert: 3		
Temperature Sensor Alerts						
Date/Time (Pacific)	Nearest Address	Scenario	Event			
09/17/2013 04:25:57PM	(Contigo) 1025 Hamilton St. Vancouver, BC, CANADA, V6B 5T4	Temp Sensor	Below threshold (42 °F)			
09/17/2013 04:23:49PM	(Contigo) 1014 Homer St. Vancouver, BC, CANADA, V6B 2W9	Temp Sensor	Above threshold (106 °F)			
09/17/2013 04:17:57PM	(Contigo) 428 Nelson St. Vancouver, BC, CANADA, V6B 6K6	Temp Sensor	Below threshold (34 °F)			

This report shows an example of a Defective Temperature Sensor event in the EDR.

Event Detail Report – Defective Temperature Sensor

Event Detail Report				cancel	print	export...
Time Period: 09/17/2013 02:00PM to 09/17/2013 03:00PM Item Name: 1915-Office3 Beacon Name: 1915-Office3 Grouped By: Event				Report Summary Defective Temp Sensor: 1		
Defective Temp Sensor:						
Date/Time (Pacific)	Nearest Address	Scenario	Event			
09/17/2013 02:39:17PM	(Contigo) 425 Nelson St. Vancouver, BC, CANADA, V6B 6K6	Temp Sensor	Found Defective Temp Sensor			

4. Important Considerations

- Only one temperature sensor may be connected to the beacon at this time.
- The system checks the sensor to determine whether or not it is defective whenever the beacon detects an ignition-on event. In order for proper diagnosis to occur, an ignition scenario should be created for the beacon.
- If the sensor is found to be defective, the Defective Temperature Sensor event may be coupled with a Temperature Sensor Alert event with a temperature reading of 185 F (85 C), which is the maximum temperature the sensor can read.

If you are still experiencing difficulty obtaining appropriate readings from the temperature sensor after following the steps in this document, please contact Support at info@movinongps.com.